

INTRODUCTION

WARNING

Please follow these installation instructions carefully in order to avoid a safety hazard, severe injury, death, and/or substantial property damage.

- Do NOT allow exhaust flue gases to vent through the neutralizer. Fill the neutralizer unit and traps with tap water. Flue gas leakage can cause injury or death from carbon monoxide.
- The neutralizer must be located at a lower elevation than the condensate drain on the appliance to ensure proper flow of condensate through the drain line.
- Connection to the appliance and neutralizer must be installed to ensure that no condensate backflow can occur into the appliance.

INCLUDED PARTS AND DIMENSIONS

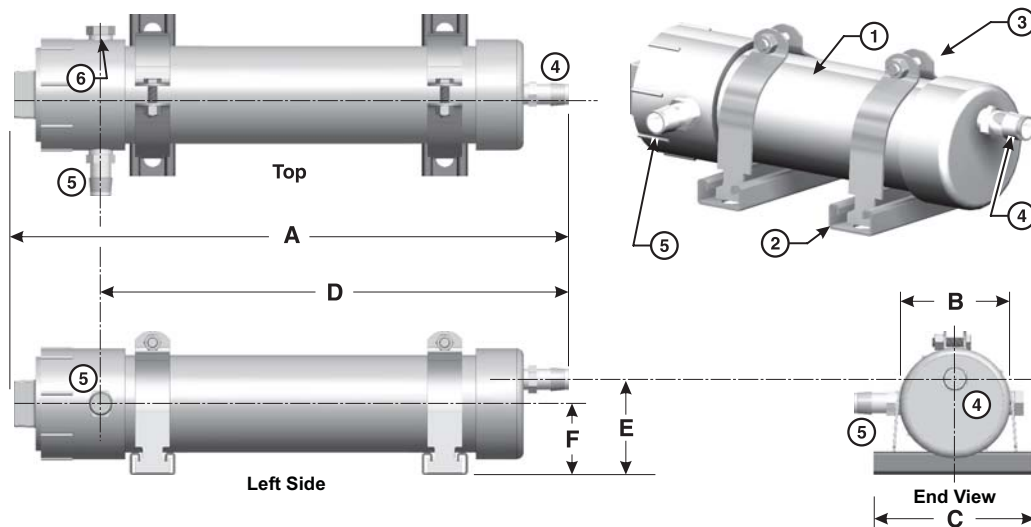

RATINGS & DIMENSIONS (in inches)								
Model	MBH	GPH	A	B	C	D	E	F
GXXX001324	1,000	10	19	4	6	16 1/8	3 1/2	2 1/2
SPECIFICATIONS								
<i>Light Commercial Neutralizer Part No.:</i> GXXX001324								
<i>Replacement Media Part No.:</i> GXXX001328								
<i>Max Flow Rate:</i> 10 gph (38 lph)								
<i>Weight:</i> 10 lbs (4.5 kgs) with media								

Item	Description of Included Parts	
1	Clear tubing filled with magnesium oxide pellets	
2	Channel strut mounts	
3	Galvanized strut clamps, bolts and nuts	
4	Condensate outlet hose barb fitting	3/4" hose barb x 1/2" NPT
5	Condensate inlet hose barb fitting	
6	Alternate location for condensate inlet hose barb fitting (plug)	

PREPARE FOR INSTALLATION

- Up to **SIX (6)** Navien appliances can be connected to a single Light Commercial Neutralizer unit. For all other appliances, please see the manufacturer's installation instructions for more information.
- The neutralizer INLET has a center connection port on the side of the unit and the OUTLET has an offset connection. Make sure that the neutralizer unit is located **BELOW** the condensate drain port on the appliance. Relocate and elevate the appliance above the neutralizer if necessary.
- Install the neutralizer using the included mounting accessories in a suitable area where a drain can be easily accessible. Securely fasten the two mounting clamps to the floor or wall and provide sufficient spacing between the two clamps (6 1/2 inch spacing is recommended).

NOTE: Do **NOT** mount the neutralizer in a **VERTICAL** position.

If a drain is not located within a close distance, use a condensate pump to direct flow to a proper drain.

- Pull the clamps apart to allow the neutralizer to be inserted. Verify the INLET and OUTLET locations on the neutralizer before completing the mounting procedure. Tighten the clamps to secure the unit in place.

INSTALLATION

- Connect the appropriate corrosion resistant pipe materials to the neutralizer and secure the drain piping to the floor by using clamps to prevent movement. Apply Teflon tape on all threaded plastic fittings.
- Connections to the appliance and neutralizer unit must be installed to ensure that no condensate backflow can occur.

NOTE: Do not route the condensate line through any area that is exposed to freezing temperatures. If personnel traffic poses a risk, install some protection to prevent movement and/or damage.

- Route the neutralizer outlet piping to an appropriate drain. If a drain is not available nearby, install a condensate removal pump to route the condensate to a suitable location.
- Access to the discharge is necessary for proper maintenance in order to check the effectiveness of the neutralizing media using pH test strips.

NOTE: Always consult the local authority regarding any requirements concerning flue gas condensate handling codes.

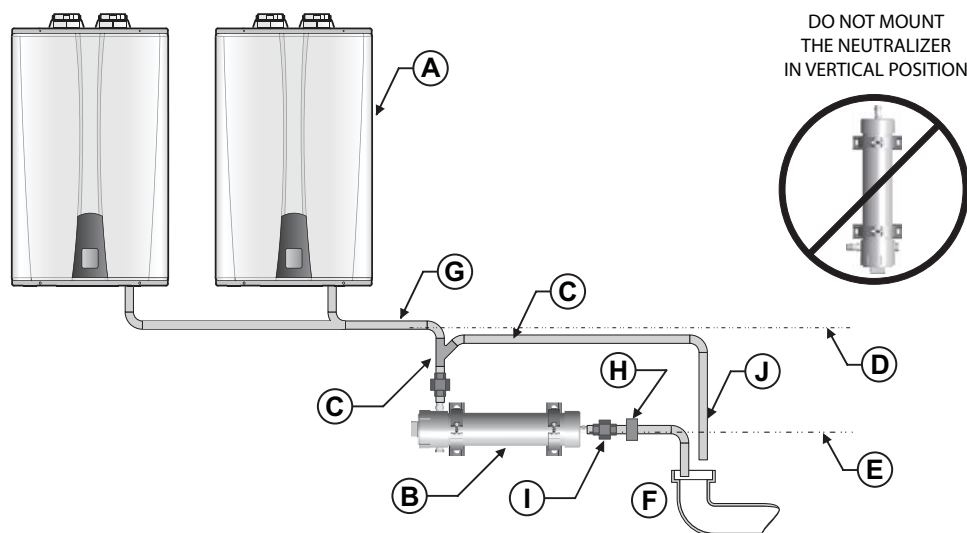

- | | | |
|--|---|--|
| A. Condensing Appliance | E. Bottom of the neutralizer condensate outlet | H. Secure condensate piping in place with clamps if necessary (follow instructions for mounting of condensate pump, when used) |
| B. Neutralizer (wall or floor mounted) | F. Route discharge to floor drain or to an appropriate drain location | I. Install a union at each connection to the neutralizer unit to allow for removal and servicing as needed |
| C. Optional Y-fitting (3/4" PVC minimum located a minimum of 2 inches above the neutralizer) for an overflow drain line placed below the bottom of the condensate drain line | G. PVC pipe – Include unions on the drain line to allow removal of the tank for inspection and service. Secure pipe in place – protect with a shield if necessary if routed through traffic areas | J. Terminate the overflow line above the drain location so any flow from the line is easily visible |
| D. Bottom of the condensate outlet from the appliance MUST be ABOVE the bottom of the neutralizer outlet | | |

Example of a Multi-Unit Navien Cascade Setup with Light Commercial Neutralizer Kit

MAINTENANCE

- Monitor the level of the neutralizer media in the unit periodically. Check the pH level at the outlet of the neutralizer kit annually and use a suitable pH test strip paper or an electronic pH meter for precise measurements. The neutralizing media should be replaced when the pH level drops below the minimum level of the local water authority (media replacement is recommended for pH levels below 6.0). For replacement media, contact Navien America or your local Navien dealer.

LIMITED WARRANTY

- The unit is warranted against defects in materials and workmanship for **ONE YEAR**. The warranty does NOT cover issues that result from misuse, improper installation, and/or failure to replace the media.